

NOTES:

1. MATERIAL: GRADE A NICKEL, .010 ± .0005 STARTING GAGE
2. PARTS MUST BE FREE AND CLEAN OF CONTAMINANTS INCLUDING SOLVENTS & OILS.
3. PARTS TO BE FREE OF SRATCHES, DENTS & BURRS PER MANUFACTURING PLANTS VISUAL STANDARDS.

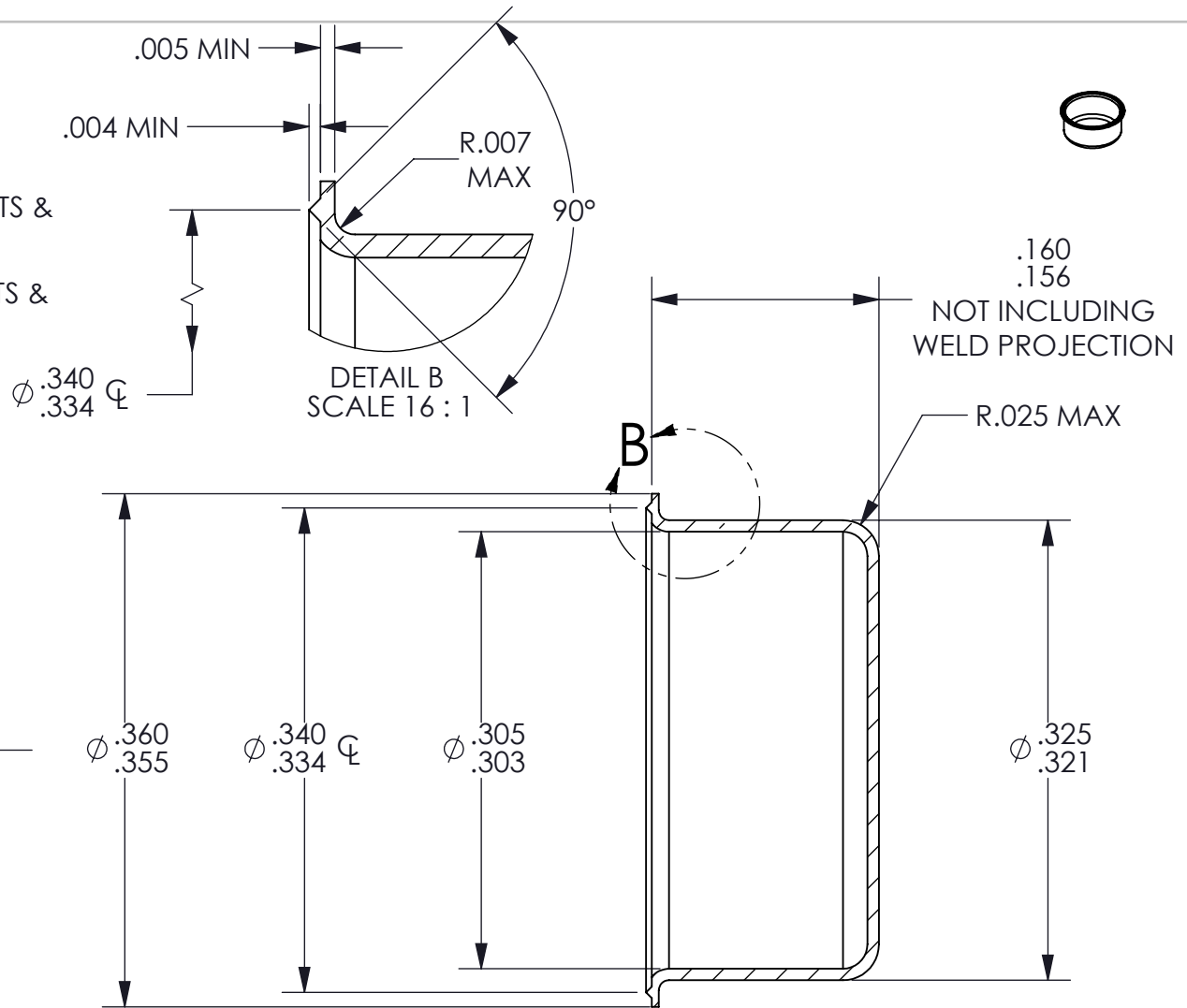

SECTION A-A



RMP# 6801

RICARDS METAL PRODUCTS INC.
WOLCOTT, CONNECTICUT

CONFIDENTIAL PROPERTY OF
RICHARDS METAL PRODUCTS INC.
DO NOT DISCLOSE TO OTHERS, COPY,
OR REPRODUCE WITHOUT WRITTEN
PERMISSION.

DESC: T0-5 CAP LOW PROFILE		CUST. #:	
ENG. MGR:	SALES:	MFG. MGR:	QUAL. MGR:
DATE:	DATE:	DATE:	DATE:
DRAWN: F.H.G.	DATE: 9/17/14	SCALE: 8:1	COMBO:

LET	REVISIONS	DATE	BY

DWG PER ANSI/ASME Y14.5-1994(R2004)