

NOTE:

- 1. MATERIAL: ASTM F-15 ALLOY
PER MIL-I-23011.
- SEAL 1ST PC: 1,2,3,4,6,7,8,9,11,12
13,15,20,21,22,23
- SEAL QC: 15,16,17,23
- PRE-PLATE QC: 1,3,4,6,8,9,10,16,17,21
- FQC: 5,6,16,17

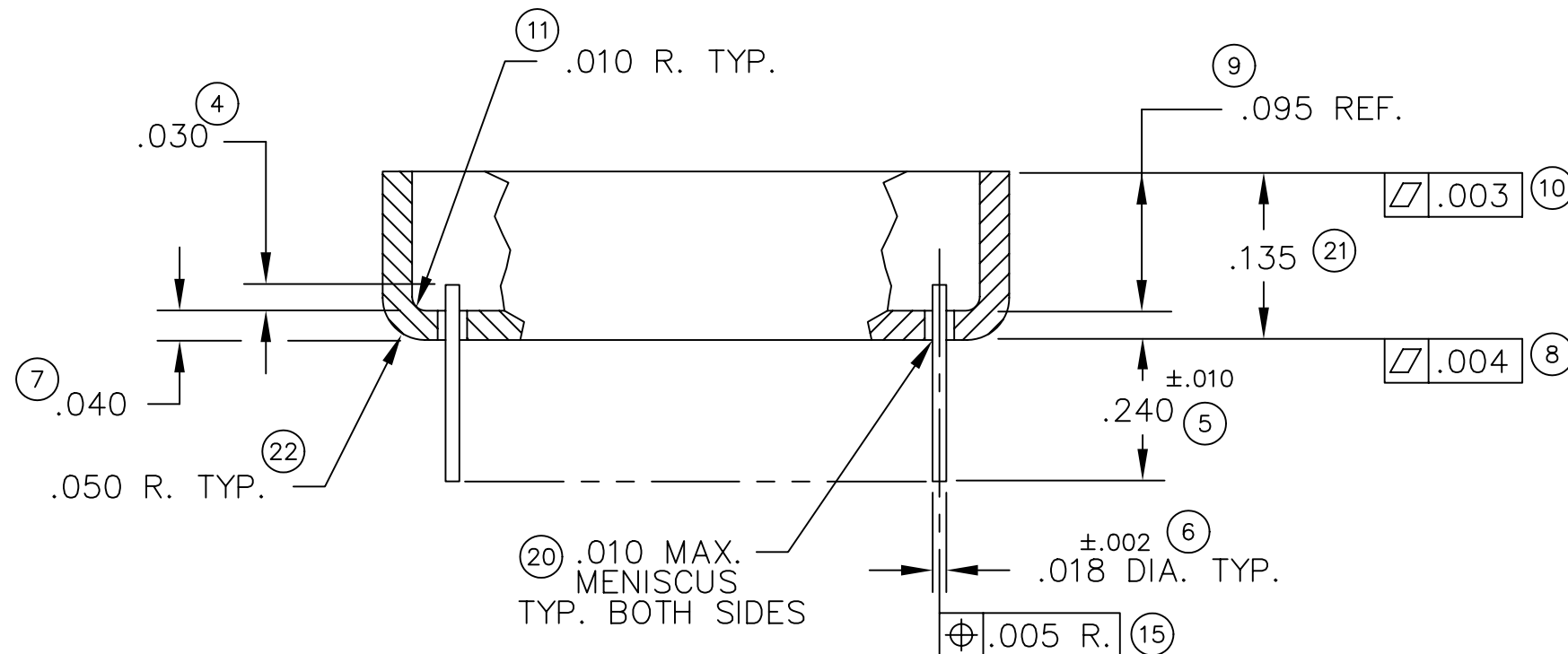

PLATING REQUIREMENTS				METRIC UNITS ARE IN BRACKETS		
	BODY / FRAME			LEADS		
	THICKNESS	TYPE	PER SPEC	THICKNESS	TYPE	PER SPEC
NICKEL	50-200 μ" [1.27-5.08 μm]	ELECTROLYTIC	QQ-N-290A	175-350 μ" [4.45-8.89 μm]	ELECTROLYTIC	QQ-N-290A
GOLD	μ" [μm]	ELECTROLYTIC	MIL-G-45204C TYPE III, GRADE A	75 MIN. μ" [1.91 MIN. μm]	ELECTROLYTIC	MIL-G-45204C TYPE III, GRADE A

UNLESS OTHERWISE SPECIFIED DIMENSIONS ARE IN INCHES		Aegis		50 WELBY ROAD NEW BEDFORD, MA. 02745	
TOLERANCES:		DRAWN BY	EJL	5/11/99	DWG NAME
2 PLACE DECIMALS ±	.01	DESIGN ENG	EJL	5/11/99	PLUG-IN BATHTUB
3 PLACE DECIMALS ±	.005	CHECKED BY	SPM	5/11/99	
ANGLES ±	1°			DWG NUMBER	PB050089EC027
FRACTIONS ±	1/32			CAGE CODE	
SURFACE FINISH (MAXIMUM)	63 ✓	MATL: NOTED		SIZE	OJ7H2
				B	