

- NOTES:
- MATERIAL: KOVAR
FINISH - 50-300 μIN GOLD OVER 50-300 μIN NICKEL (LEADS)
100-200 μIN ELECTROLESS NICKEL (BODY)
 - NAILHEADS LEADS .035 DIA HEAD x .008 THK.
 - TOLERANCES ARE ±.005 UNLESS OTHERWISE SPECIFIED
 - PIN No. 1 TO BE IDENTIFIED BY A CONTRASTING COLORED GLASS BEAD

REVISIONS			
LTR	DESCRIPTION	DATE	APPROVED
A	ISSUE		
B	E.C.O. No.0624	10/27/89	
C	E.C.O. No.0653	3/5/90	P.A.S.
D	E.C.O. No 1015	8/31/95	

PROCESSING REQUIREMENTS: AS INDICATED BY THE SUFFIX LETTER OF HYCOMP P/N ON THE PURCHASE ORDER (SEE TABLE No.1)

SUFFIX	REQUIREMENTS
-C	CLASS "-C" PRODUCT MUST BE MANUFACTURED IN ACCORDANCE WITH THIS DRAWING AS A MINIMUM TO ENSURE PRODUCT QUALITY
-B	CLASS "-B" PRODUCT MUST BE MANUFACTURED IN ACCORDANCE WITH THIS DRAWING AS A MINIMUM AND PER HYCOMP PROCUREMENT SPECIFICATION INDICATED ON THE PURCHASE ORDER.

MASTER

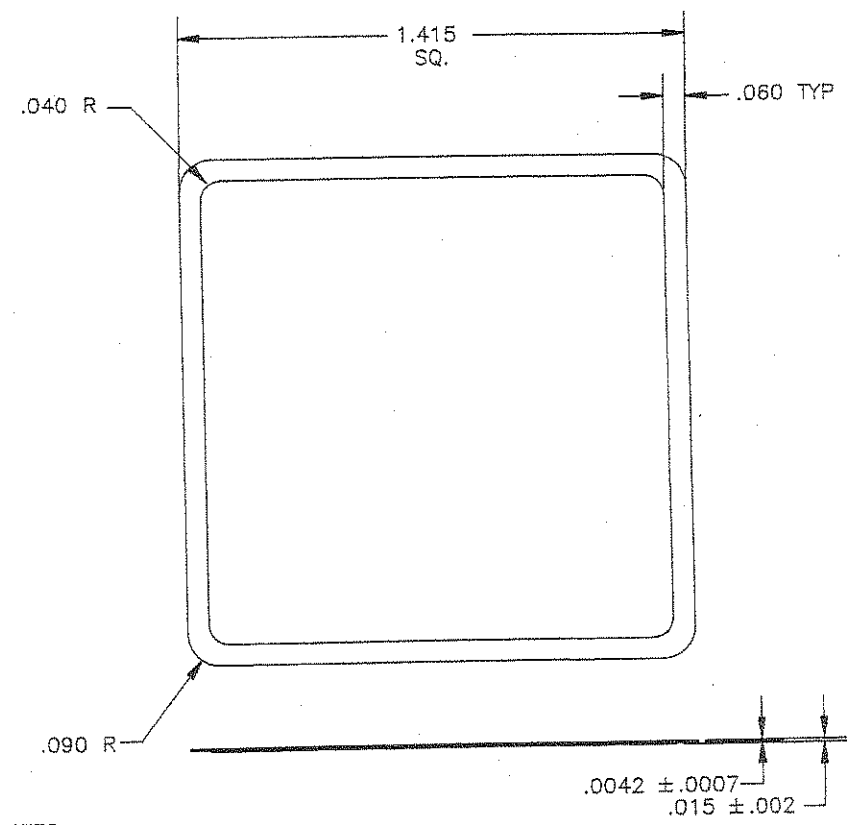

- NOTES:
- MATERIAL - KOVAR
FINISH - 50-250 μIN ELECTROLESS NICKEL
 - UNLESS OTHERWISE SPECIFIED TOLERANCES ARE ±.005

LID, STEP
1.415 X 1.415 X .015
LI0092-AEB- 3X

UNLESS OTHERWISE SPECIFIED DIMENSIONS ARE IN INCHES TOLERANCES ARE: FRACTIONS DECIMALS ANGLES ± .XX ± .XXX ±.005 ±	INITIAL APPROVALS		165 CEDARHILL ST. MARLBORO MA. 01752
	DEPT	DATE	
	ORIG	DATE	
	CHECK	DATE	
MATERIAL	PROD ENGR	MFG ENGR	TITLE PKG,26 PIN TUB 1.420 x 1.420 x .170
SEE NOTE 1	QC	QC	
FINISH			
DO NOT SCALE DRAWING	FSCM NO	SIZE	REV
	34707	C	D
	SCALE 5X	SHEET	1 OF 1