

THIS METALLIZED AREA IS CONNECTED TO DIE ATTACH PAD.(PART No.1 ONLY)

R .050 NOTCH
GRIND AFTER Au PLATING.

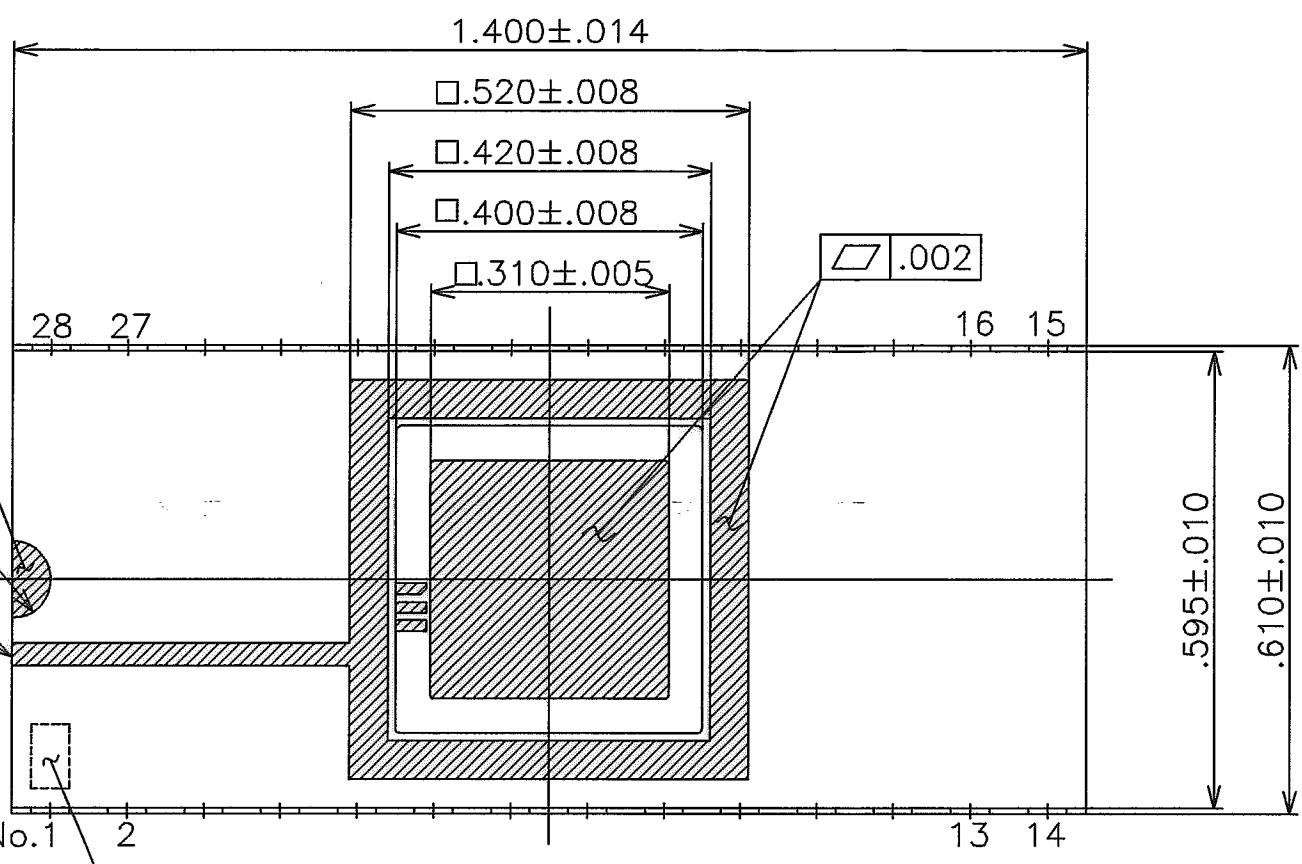

PART No.	I.D MARK	LEAD TIED DOWN	NOTCH AREA METALLIZED
01		NIL	WITH METALLIZATION
02		NIL	WITHOUT METALLIZATION

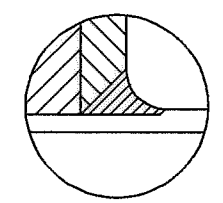
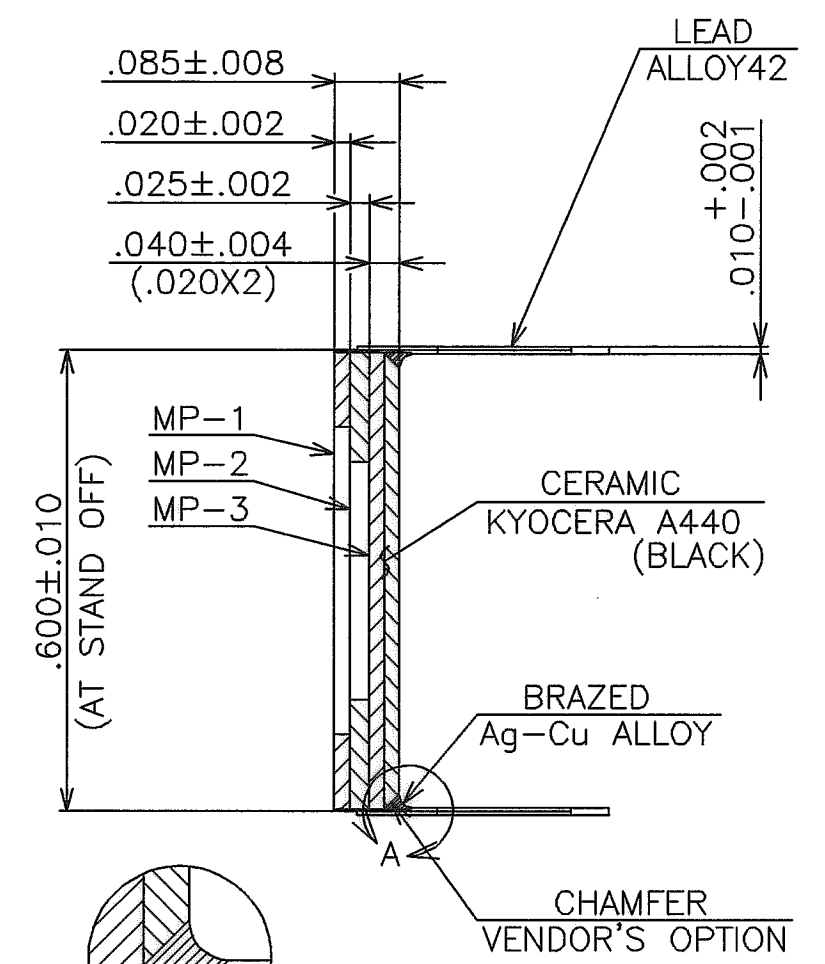

DETAIL-A

NOTES :

1. PLATING THICKNESS TO BE PER CUSTOMER'S SPECIFICATION.
2. LEAD RESISTANCE : 0.3 OHM MAX.
3. SEAL AREA TO BE METALLIZED.
4. DIE ATTACH AREA TO BE METALLIZED.
5. SEAL RING AND DIE ATTACH TO BE FLOATING FROM ANY PINS.

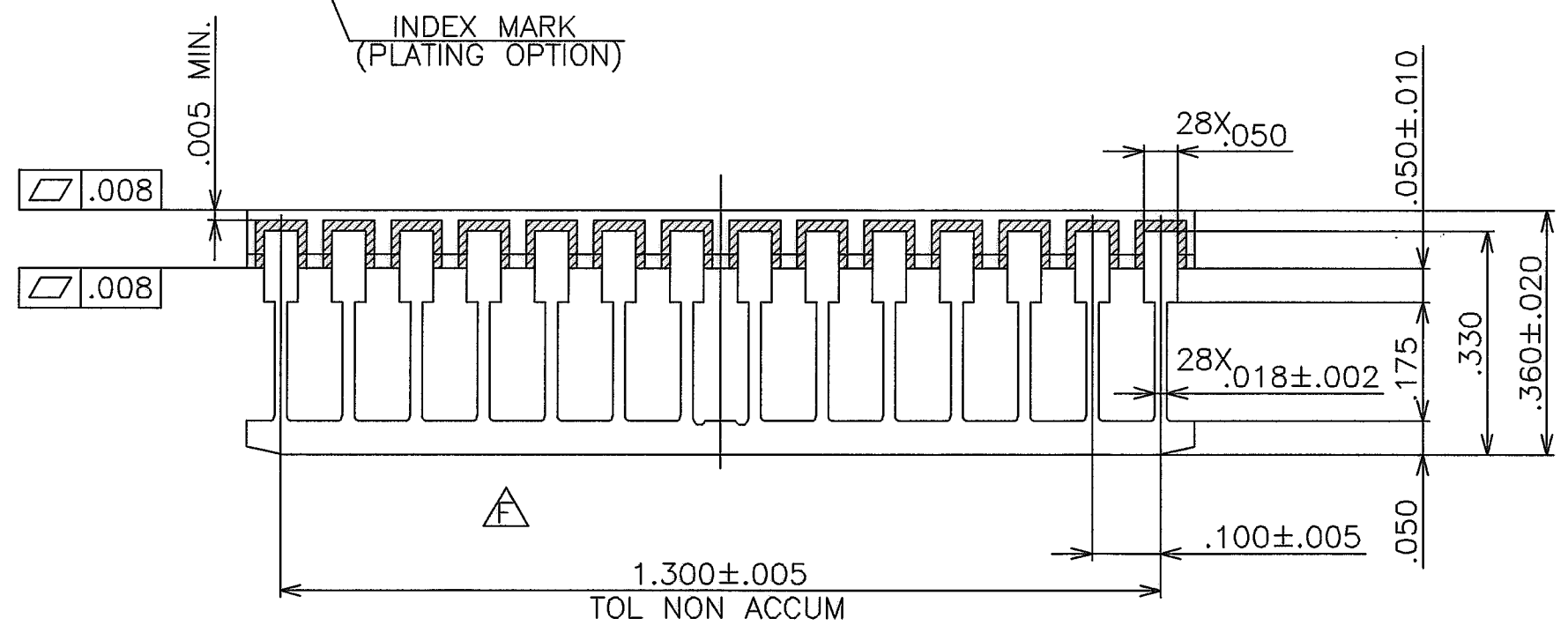

SB028L533-2	S=0
	D=0
SB028L533-1	S=0
	D=0

MODIFICATION						NAME	TOLERANCE	DRAWN	CHECKED	APPROVED	DATE
						28 LEAD SIDE BRAZED PACKAGE	UNLESS OTHERWISE SPECIFIED	K.I	K.O	M.M/T.A	JUN.18.'87
	ADDED : PART No.02 SHEET No.5,7 DELETED : VENDOR'S OPTION. CHANGED : LEAD TIE BAR.	APR.07.'11	M.S	K.Y	S.NI	SCALE 4 / 1	±.005	Yokabe			
	REDRAWN : CONVERTED CAD DATA. ADDED : SHEET 3/5	MAR.19.'01	T.S/H.K	S.K/S.NI	H.SA	MATERIAL AS INDICATED	THIRD ANGLE PROJECTION				
	CHANGED	DATE	DRAWN	CHECKED	APPROVED		KYOCERA CORPORATION KYOTO JAPAN	DRAWING NO.		SHEET	
								KD-S81533-F		1 / 7	

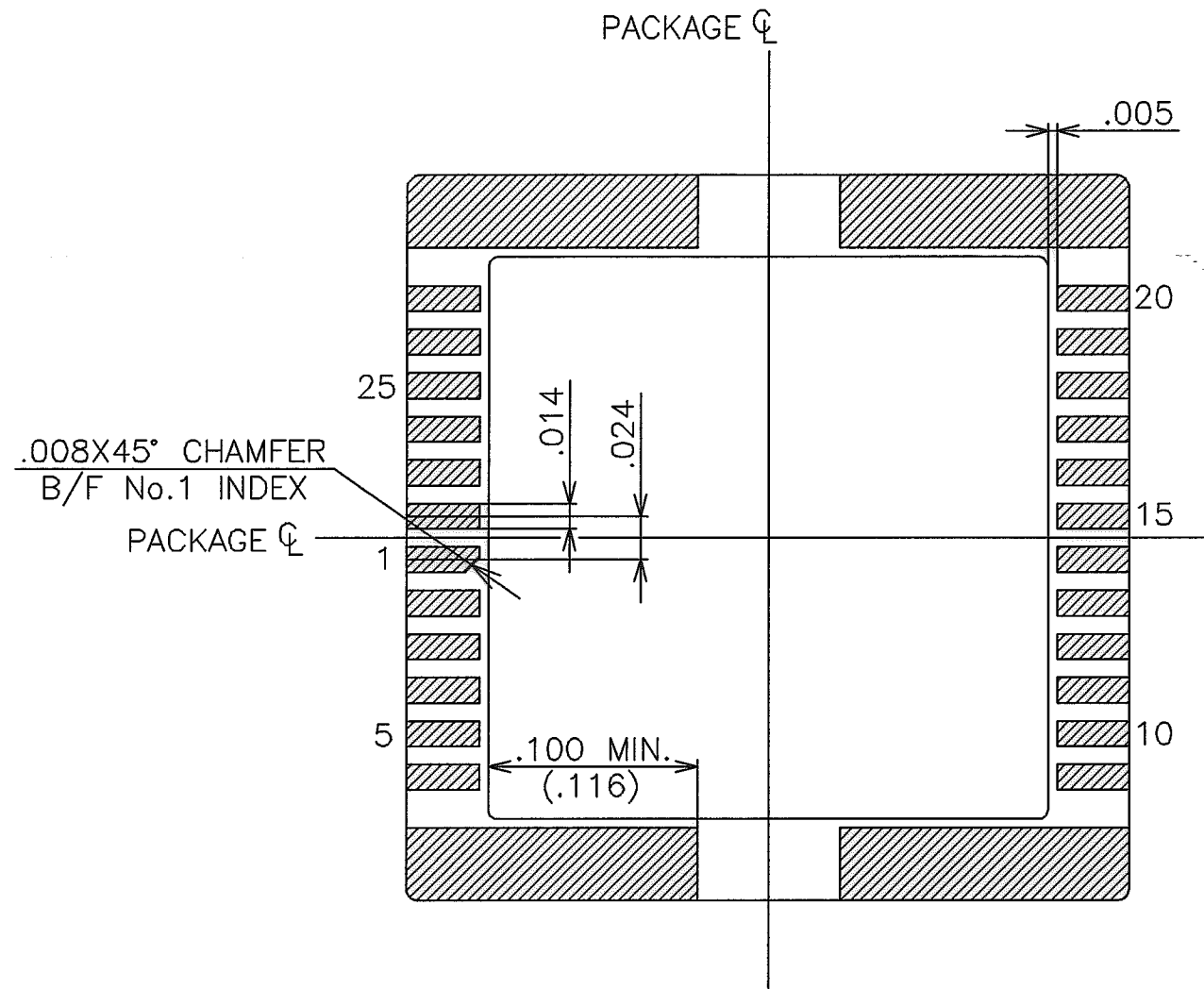

BONDING PATTERN

MODIFICATION						NAME	TOLERANCE	DRAWN	CHECKED	APPROVED	DATE
						28 LEAD SIDE BRAZED PACKAGE	UNLESS OTHERWISE SPECIFIED	K.I	K.O	M.M/T.A	JUN.18.'87
						SCALE 10 / 1	MATERIAL				
	REDRAWN : CONVERTED CAD DATA. CHANGED	MAR.19.'01	T.S/H.K	S.K/S.NI	H.SA	KYOCERA CORPORATION KYOTO JAPAN	THIRD ANGLE PROJECTION	DRAWING NO.		SHEET	
		DATE	DRAWN	CHECKED	APPROVED			KD-S81533-F		2 / 7	

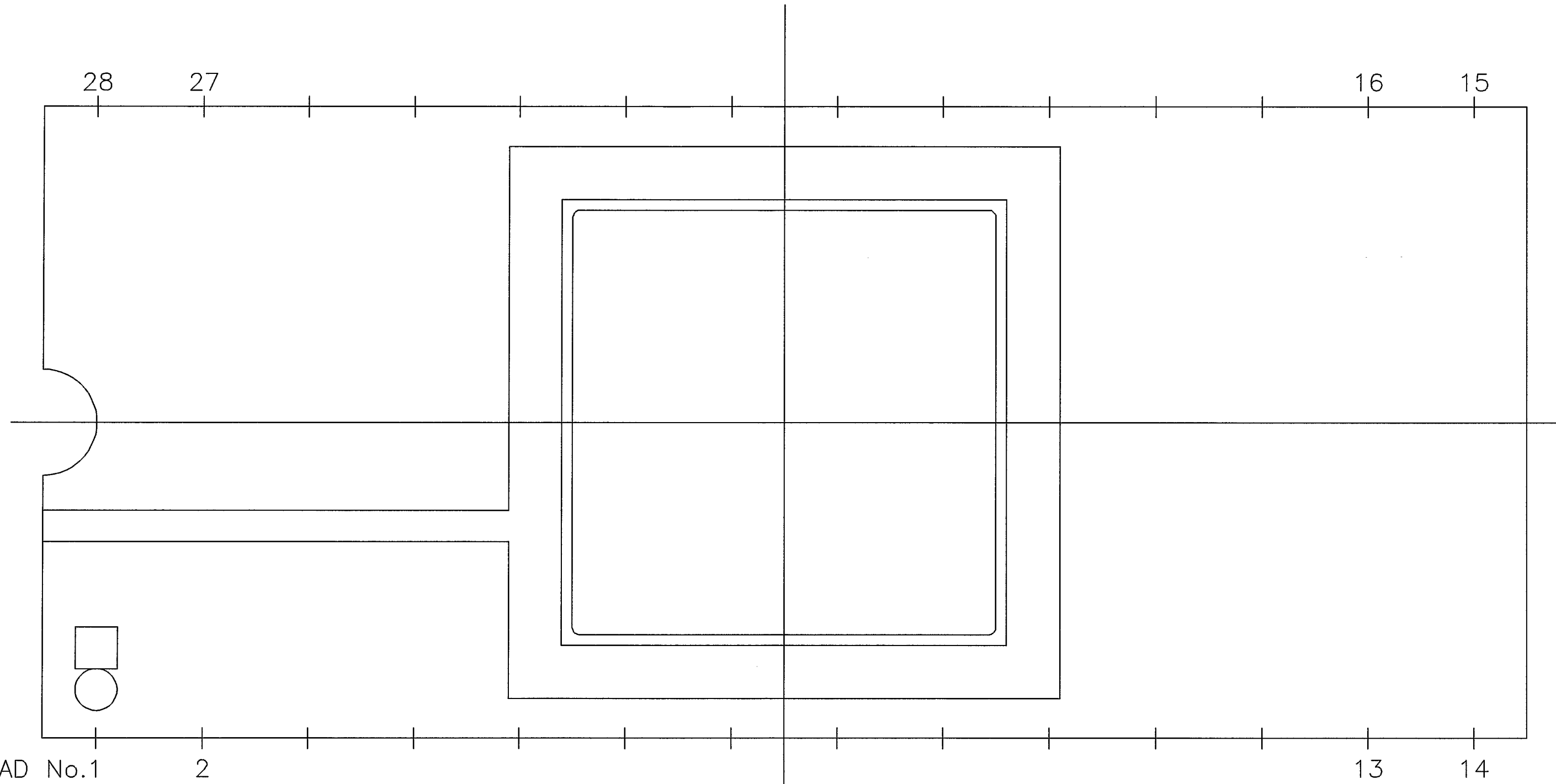

MP-1
△(PART No.01,02)

MODIFICATION						NAME 28 LEAD SIDE BRAZED PACKAGE	TOLERANCE UNLESS OTHERWISE SPECIFIED	DRAWN K.I	CHECKED K.O	APPROVED M.M/T.A	DATE JUN.18.'87
	△	ADDED : PART No.02	APR.07.'11	M.S	K.Y	S.NI	SCALE 10 / 1	MATERIAL			
	△	ADDED : THIS SHEET	MAR.19.'01	T.S/H.K	S.K/S.NI	H.SA	KYOCERA	KYOCERA CORPORATION KYOTO JAPAN	DRAWING NO. KD-S81533-F		SHEET 3 / 7
		CHANGED	DATE	DRAWN	CHECKED	APPROVED					

THIRD ANGLE PROJECTION

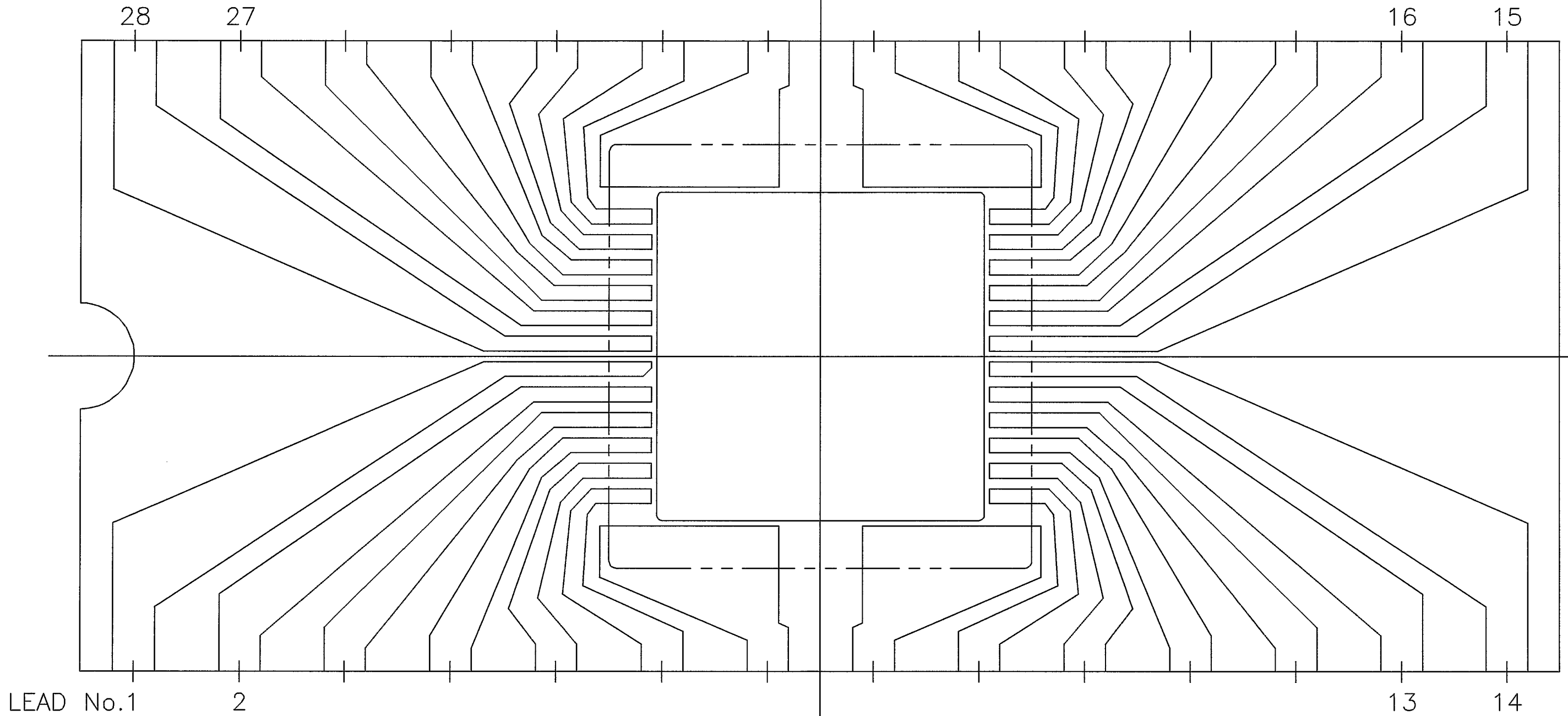

MP-2
(PART No.01)

MODIFICATION						NAME	TOLERANCE	DRAWN	CHECKED	APPROVED	DATE
						28 LEAD SIDE BRAZED PACKAGE	UNLESS OTHERWISE SPECIFIED	K.I	K.O	M.M/T.A	JUN.18.'87
						SCALE 10 / 1	MATERIAL	<i>T. Okabe</i>	<i>[Signature]</i>	<i>[Signature]</i>	
							THIRD ANGLE PROJECTION				
	△ REDRAWN : CONVERTED CAD DATA. CHANGED	MAR.19.'01	T.S/H.K	S.K/S.NI	H.SA	KYOCERA	KYOCERA CORPORATION KYOTO JAPAN	DRAWING NO.		SHEET	
		DATE	DRAWN	CHECKED	APPROVED			KD-S81533-F		4 / 7	

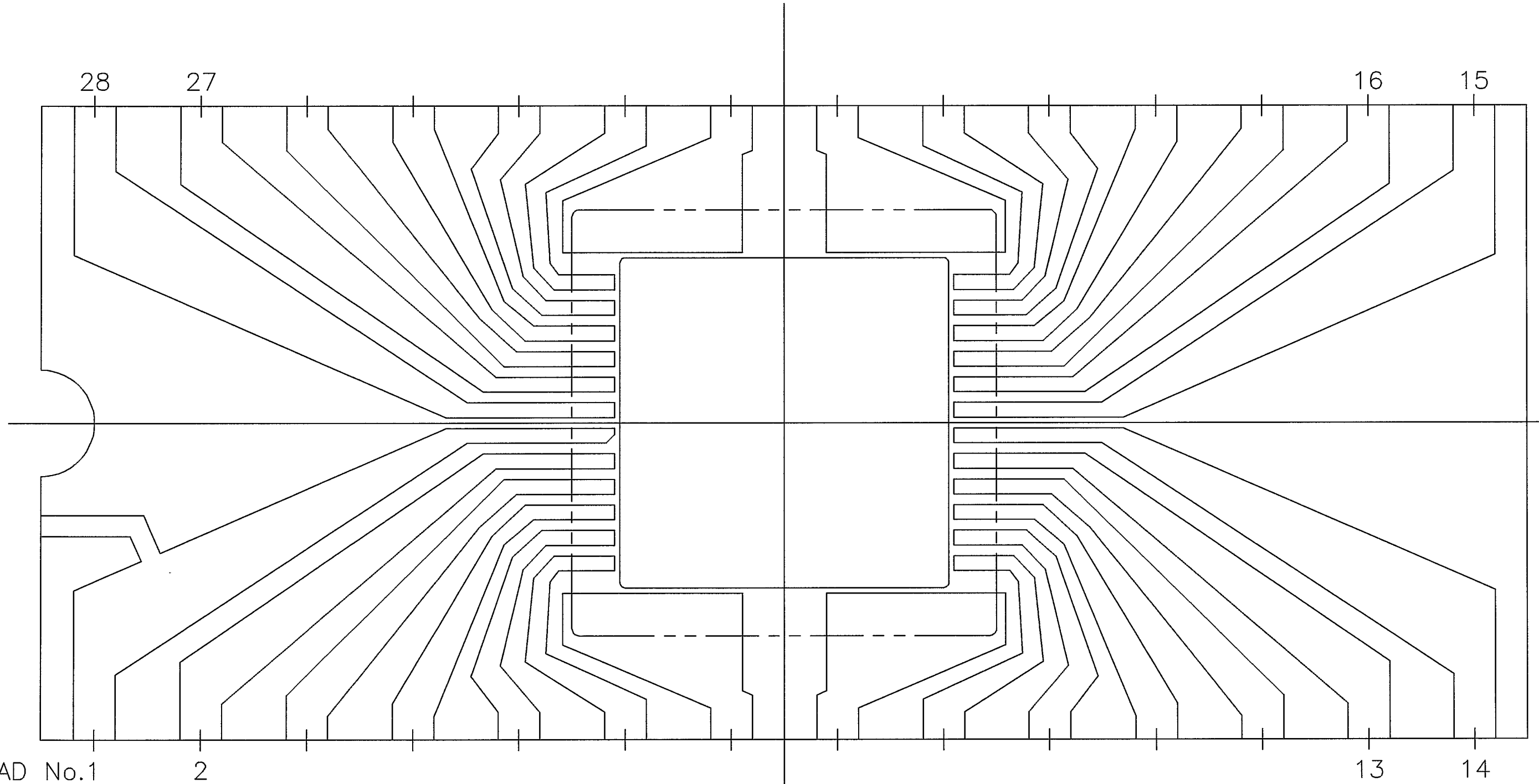

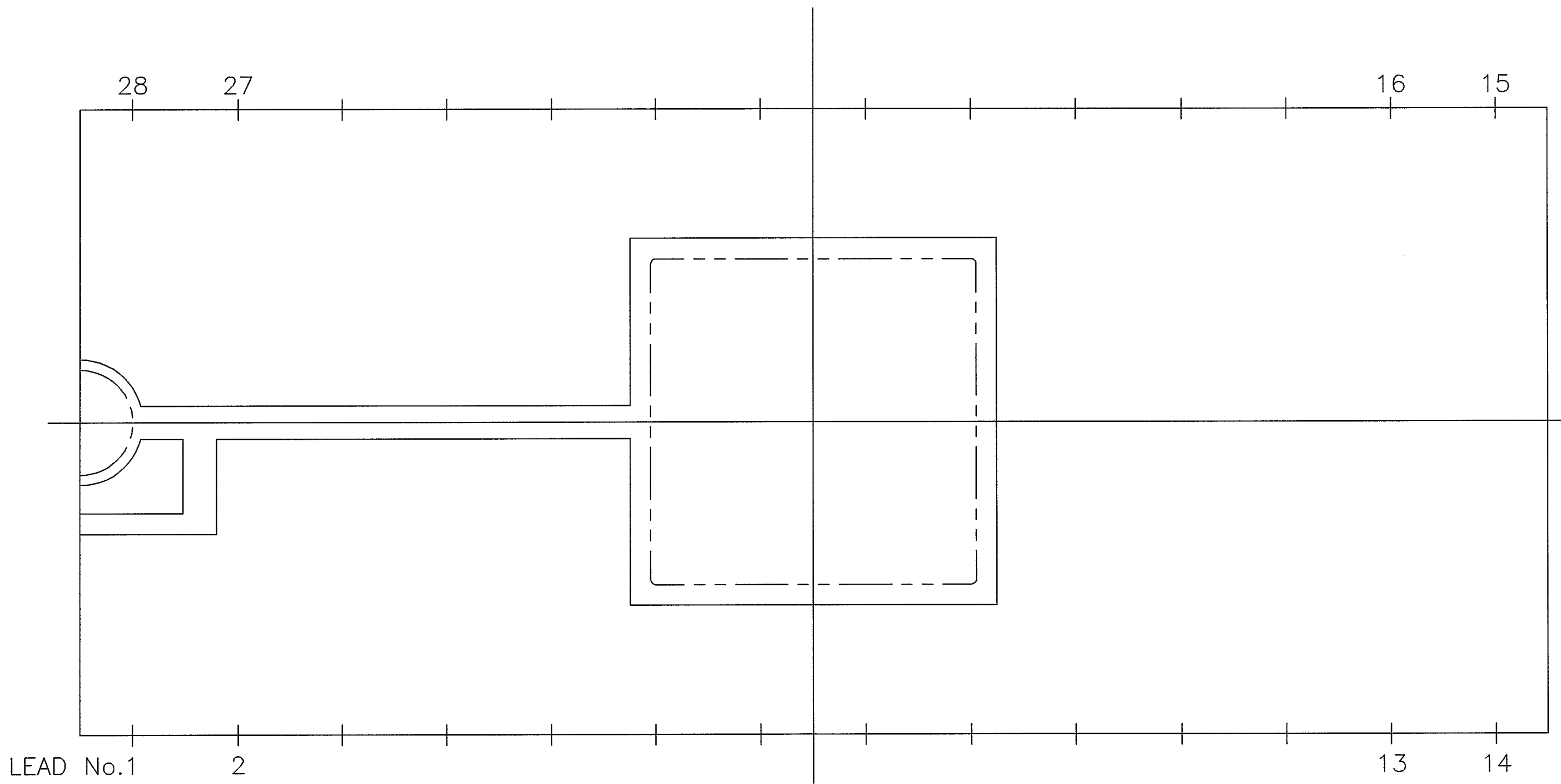

MP-2
(PART No.02)

MODIFICATION						NAME 28 LEAD SIDE BRAZED PACKAGE	TOLERANCE UNLESS OTHERWISE SPECIFIED	DRAWN K.I	CHECKED K.O	APPROVED M.M/T.A	DATE JUN.18.'87
						SCALE 10 / 1	MATERIAL				
										THIRD ANGLE PROJECTION	
	ADDED : THIS SHEET. CHANGED	APR.07.'11	M.S	K.Y	S.NI		KYOCERA CORPORATION KYOTO JAPAN	DRAWING NO. KD-S81533-F		SHEET 5/7	



MP-3
(PART No.01)

MODIFICATION						NAME 28 LEAD SIDE BRAZED PACKAGE	TOLERANCE UNLESS OTHERWISE SPECIFIED	DRAWN K.I	CHECKED K.O	APPROVED M.M/T.A	DATE JUN.18.'87
						SCALE 10 / 1	MATERIAL				
										THIRD ANGLE PROJECTION	
△	REDRAWN : CONVERTED CAD DATA. CHANGED	MAR.19.'01	T.S/H.K	S.K/S.NI	H.SA		KYOCERA CORPORATION KYOTO JAPAN	DRAWING NO. KD-S81533-F		SHEET 6/7	

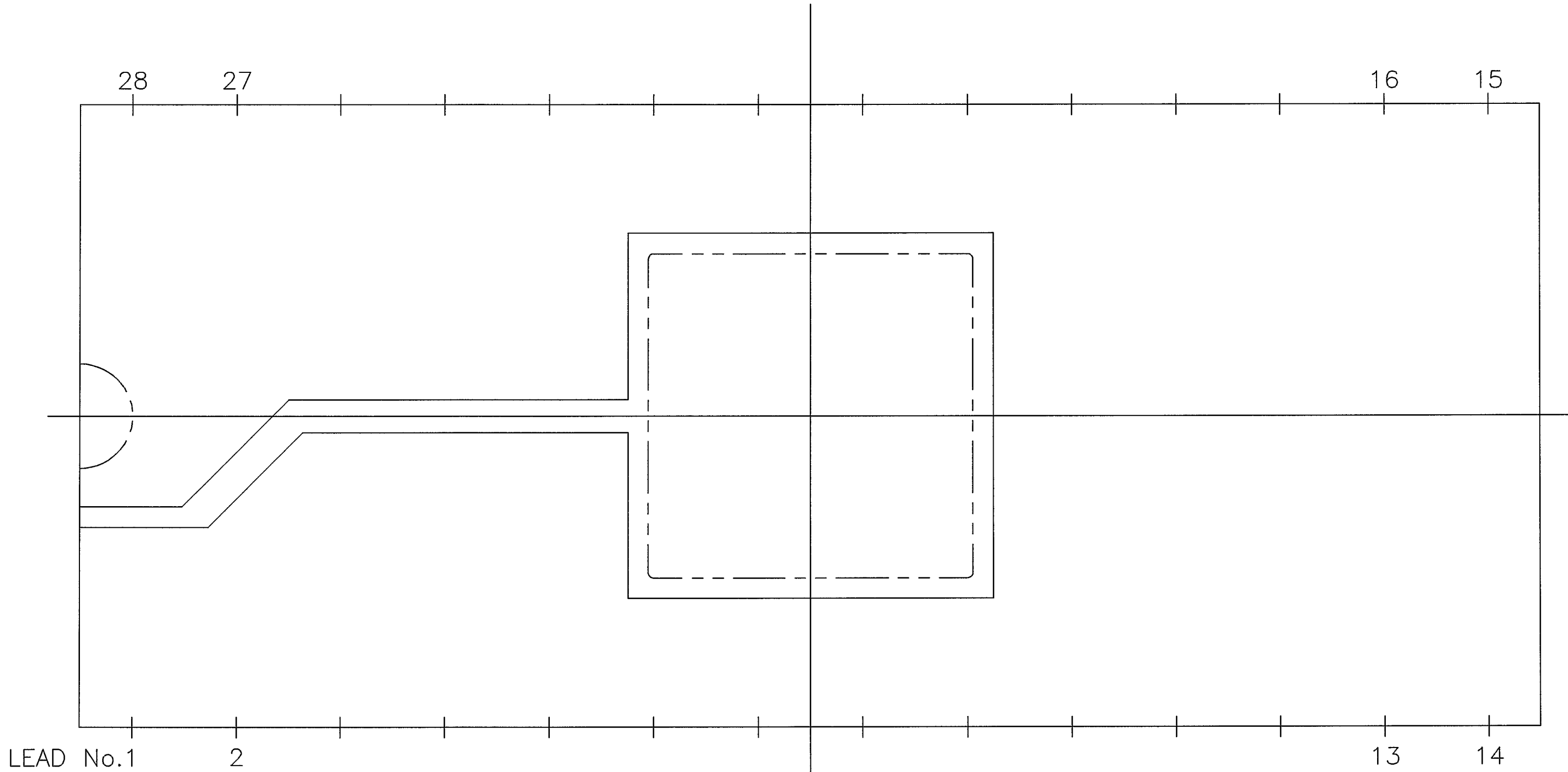

MP-3
(PART No.02)

MODIFICATION						NAME 28 LEAD SIDE BRAZED PACKAGE	TOLERANCE UNLESS OTHERWISE SPECIFIED	DRAWN K.I	CHECKED K.O	APPROVED M.M/T.A	DATE JUN.18.'87
						SCALE 10 / 1	MATERIAL	THIRD ANGLE PROJECTION	<i>Y. Okabe</i>	<i>T. Yano</i>	
	ADDED : THIS SHEET.	APR.07.'11	M.S	K.Y	S.NI		KYOCERA CORPORATION KYOTO JAPAN		DRAWING NO. KD-S81533-F	SHEET 7 / 7	
	CHANGED	DATE	DRAWN	CHECKED	APPROVED						