

# 40 LEAD CERDIP - .600 BODY WIDTH

FADR-03048

## CAVITY SIZE OPTIONS

.300 X .280
.300 X .295
.375 X .295
.
.420 X .295

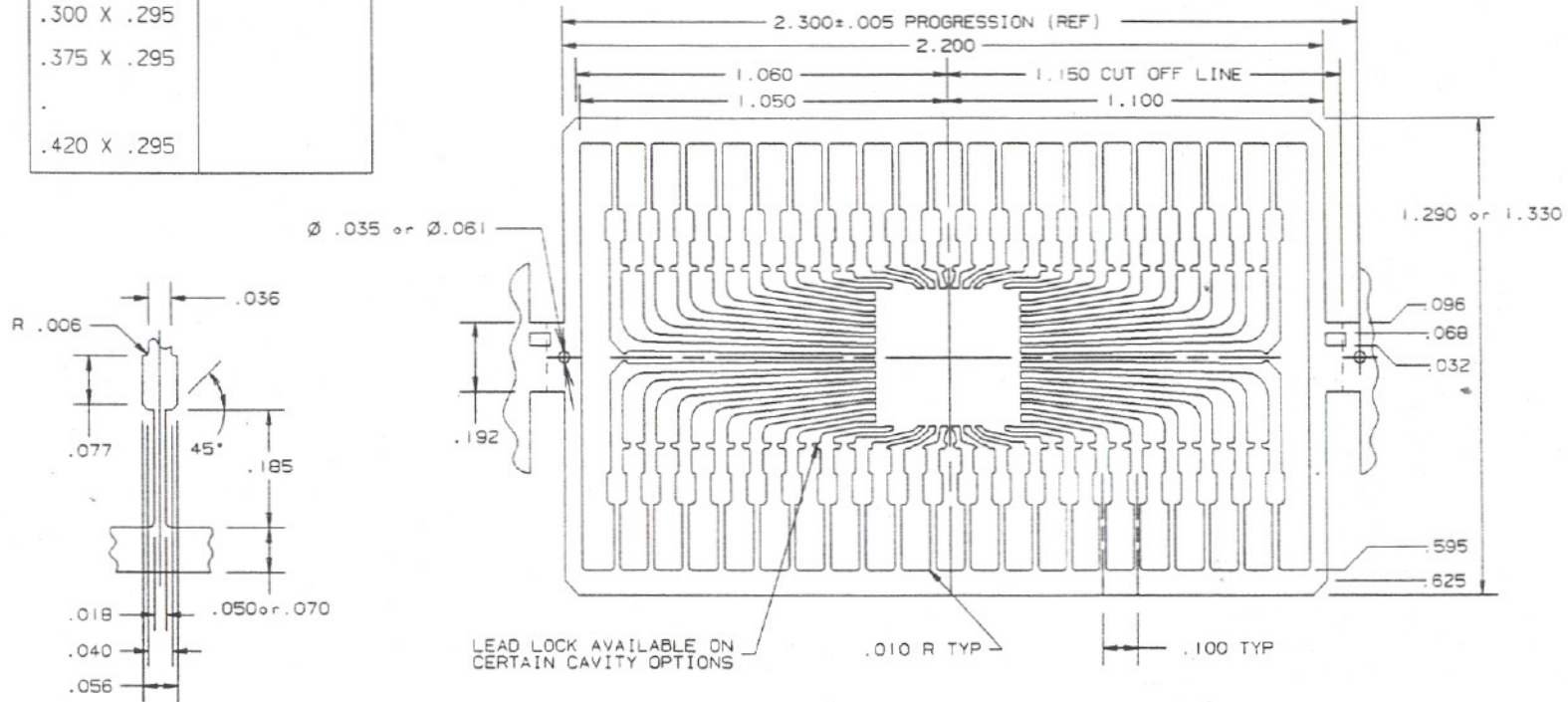

## LEAD DETAIL TYP

### Notes:

- 1.- Material thickness:  
Alloy 42: 0.010 ± 0.0005 uncoiled  
Aluminum stripe is clad.  
Aluminum: 200-500 micro inches.
- 2.- General Tolerances: 0.XXX ± 0.002
- 3.- Lead position after forming: ± 0.003
- 4.- Unspecified radii: 0.005 maximum
- 5.- All dimensions specified in inches.

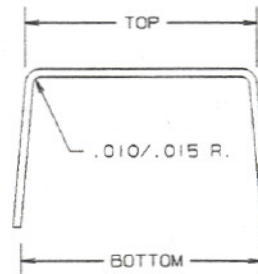

## AVAILABLE FORM OPTIONS

TOP	BOTTOM
.614 ± .003	.660 ± .015
	.680 ± .015