

# 24 LEAD CERDIP - .300 BODY WIDTH

FADR-03041

## CAVITY SIZE OPTIONS

.210 X .180	.320 X .180
.270 X .170	.430 X .170
	.530 X .175
.300 X .175	
.320 X .174	

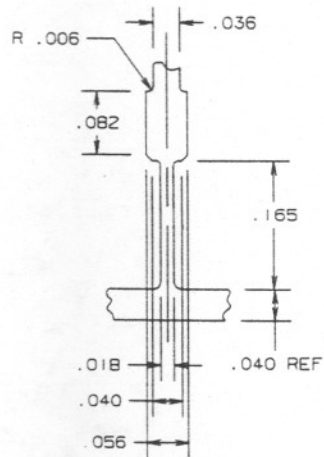

LEAD DETAIL TYP

Notes:

- Material thickness:  
Alloy 42:  $0.010 \pm 0.0005$  uncoined  
Aluminum stripe is clad.  
Aluminum: 200-500 micro inches.
- General Tolerances:  $0.XXX \pm 0.002$
- Lead position after forming:  $\pm 0.003$
- Unspecified radii: 0.005 maximum
- All dimensions specified in inches.

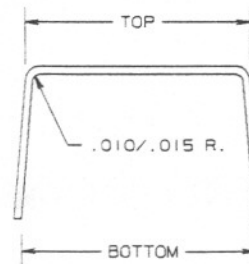
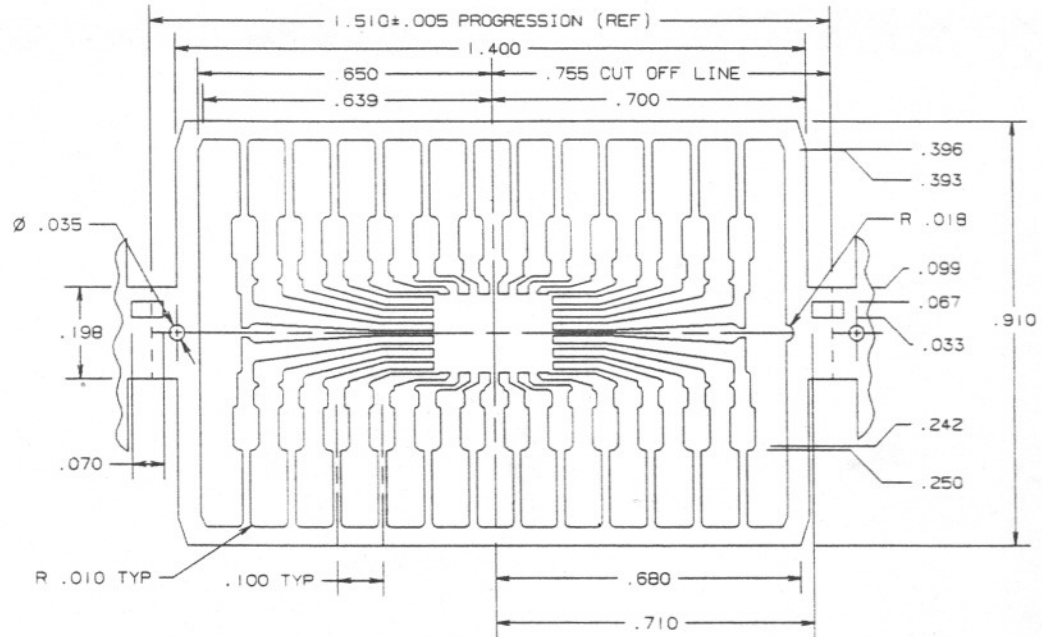

## AVAILABLE FORM OPTIONS

TOP	BOTTOM
.314 ± .003	.365 ± .015
	.385 ± .015
	.400 ± .015