

CF05306903S005

REV	QACN #	APPROVED INTS	DATE
A	00-1368	LMC	10/12/00

NOTES:

- MATERIAL:
 SEAL RING - ASTM F-15 ALLOY PER MIL-I-23011
 BOTTOM - 90% MIN. AL₂O₃ BLACK
 PADS - 85% TUNGSTEN 15% COPPER COMPOSITE MATERIAL
 BRAZE - BT (72% SILVER 28% COPPER)
 TAB - .005 THICK C102 COPPER.
- PACKAGES SHALL COMFORM TO LATEST REVISION OF OLIN AEGIS SPECIFICATION QAP-126, GENERAL SPECIFICATION FOR SURFACE MOUNT PACKAGES.
- PLATING SHALL BE 100-350" ELECTROLYTIC NICKEL PER QQ-N-290A UNDER 50-150" GOLD PER MIL-G-45204C, TYPE III, GRADE A.

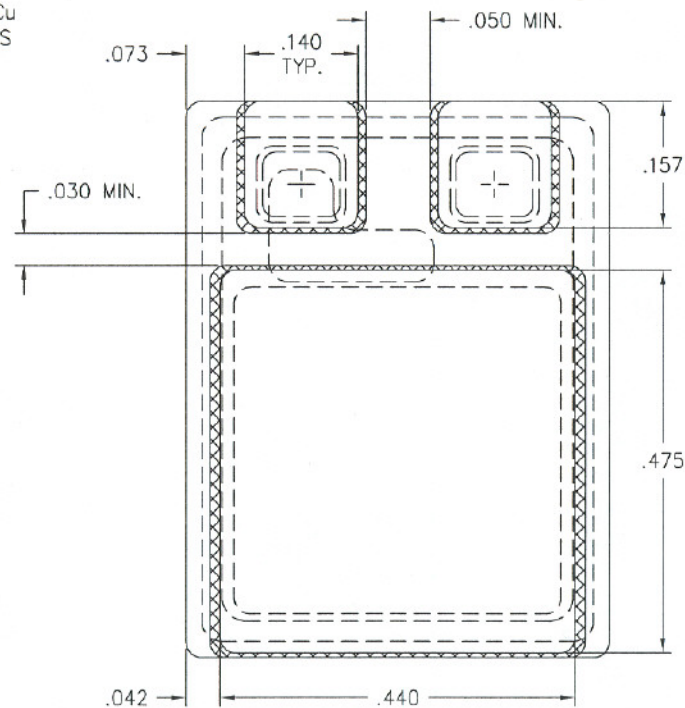
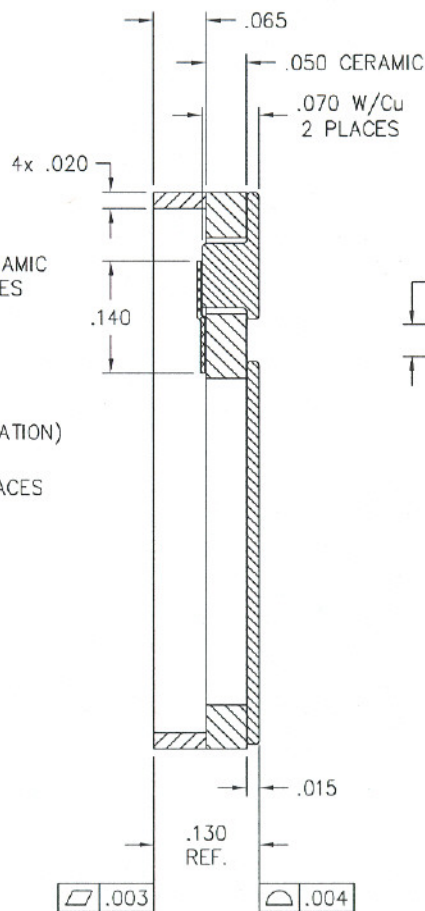
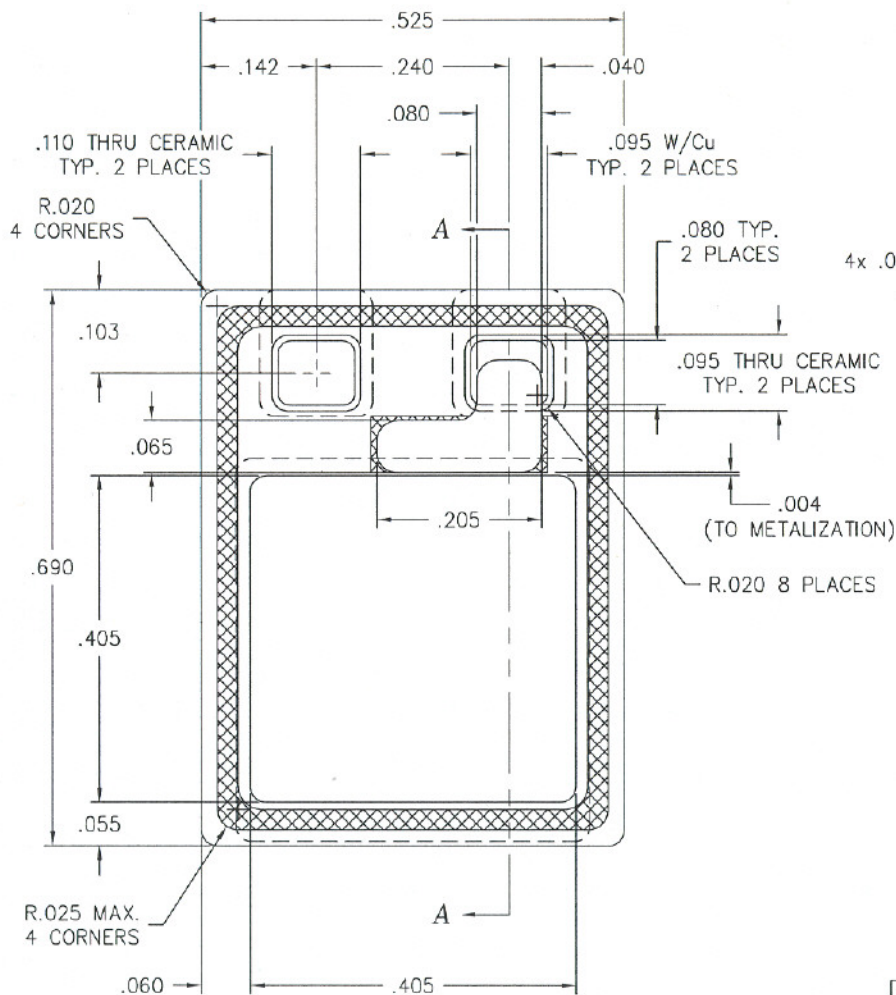

SECTION A-A

PATENET NUMBER 5,111,277

THE INFORMATION CONTAINED IN THIS DRAWING IS THE SOLE PROPERTY OF OLIN AEGIS AND ANY REPRODUCTION IN PART OR WHOLE WITHOUT THE WRITTEN PERMISSION OF OLIN AEGIS IS PROHIBITED.

UNLESS OTHERWISE SPECIFIED DIMENSIONS ARE IN INCHES		Olin Aegis 50 WELBY ROAD NEW BEDFORD, MA. 02745	
TOLERANCES:	DRAWN BY	CV	8/9/00
2 PLACE DECIMALS ± .01	DESIGN ENG	DAC	8/9/00
3 PLACE DECIMALS ± .005	APPROVED BY	LMC	8/14/00
ANGLES ± 1°	DATE	8/14/00	
FRACTIONS ± 1/32	WALT:	NOTED	
SURFACE FINISH 63 ✓	NOTE	CAGE CODE	OJ7H2
		SIZE	B
		SHEET	1 OF 1